

1" x 1/4" SLOT  
EQUALLY SPACED  
EVERY 5 3/16"

**DETAIL A**

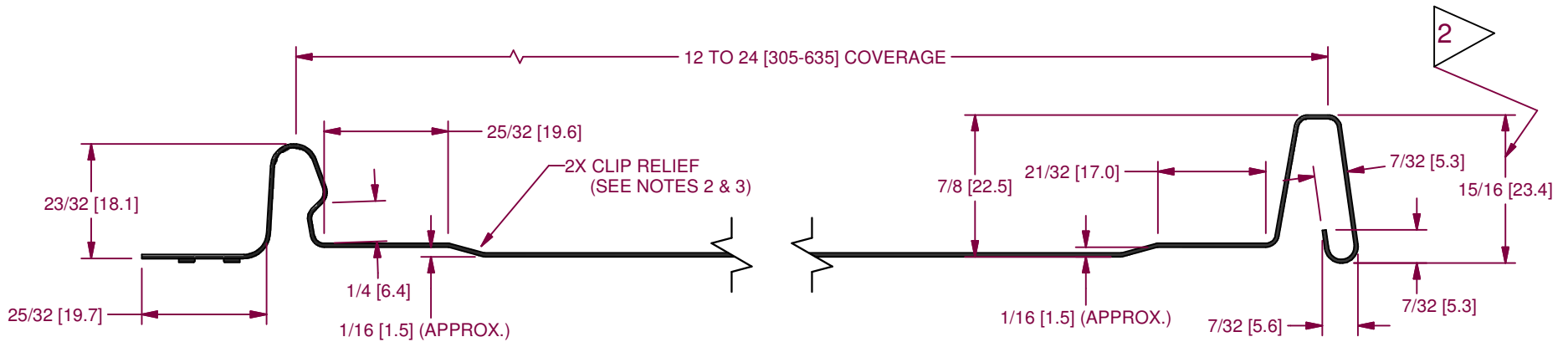
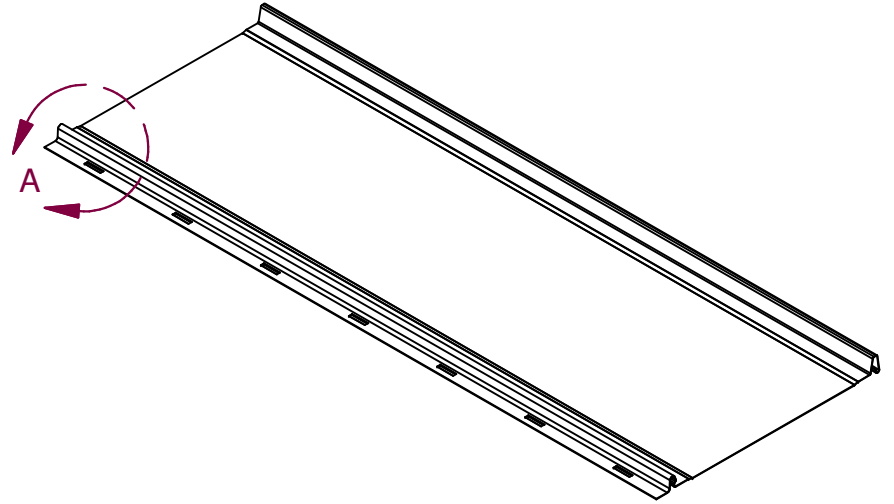

**2** INCREASED LENGTH OF LEG  
REVISED MATERIAL USAGE

- NOTES:
1. MATERIAL USAGE: 4 1/16"
  2. CLIP RELIEF ROLLERS ARE STANDARD WITH THIS PANEL.
  3. PANEL IS SHOWN WITH CLIP RELIEF ROLLERS ENGAGED.
  4. DUAL DIMENSIONS: Inch [mm]

|  |     |         |            |             |                                      |
|--|-----|---------|------------|-------------|--------------------------------------|
| MATERIAL PAINTED STEEL/PAINTED ALUMINUM/COPPER |     |         |            | FINISH NONE |                                      |
| REVISION HISTORY                               | REV | ECR NO. | DATE       | RELEASED BY | TOLERANCES                           |
|  | 1   | REDRAWN | 01/17/08   | JD          | .XX = ± .01                          |
|  | 2   | R-1796  | 09/22/2011 | AJB         | .XXX = ± .005                        |
|  |     |         |            |             | FRACTION = ± 1/32"<br>ANGLE = ± 1/2' |

|   |  |                                 |  |              |
|---|--|---------------------------------|--|--------------|
|  |  | <b>NEW TECH MACHINERY CORP.</b> |  |              |
| DRAWN BY DeBerard   |  | PART NAME FF100 PANEL PROFILE   |  |              |
| DATE 06/25/2002   |  | PART NUMBER                     |  |              |
| CHECK BY FRY  |  | FF1-FF1                         |  | SHEET 1 OF 1 |
| DATE 01/17/2008   |  | REVISION 2                      |  |              |